

PRO-LOK®

655 North Hariton Street • Orange, CA • 92868
866.679.1366 / PRO-LOK.COM

Item:
IN436-PRO



Item	Description
INCL-PRO	Professional Series Universal Clamp
IN51	Mortise Alignment + Centering Tool
INJIGC-MORT	Mortise Lock and Face Plate Installation Jig Kit

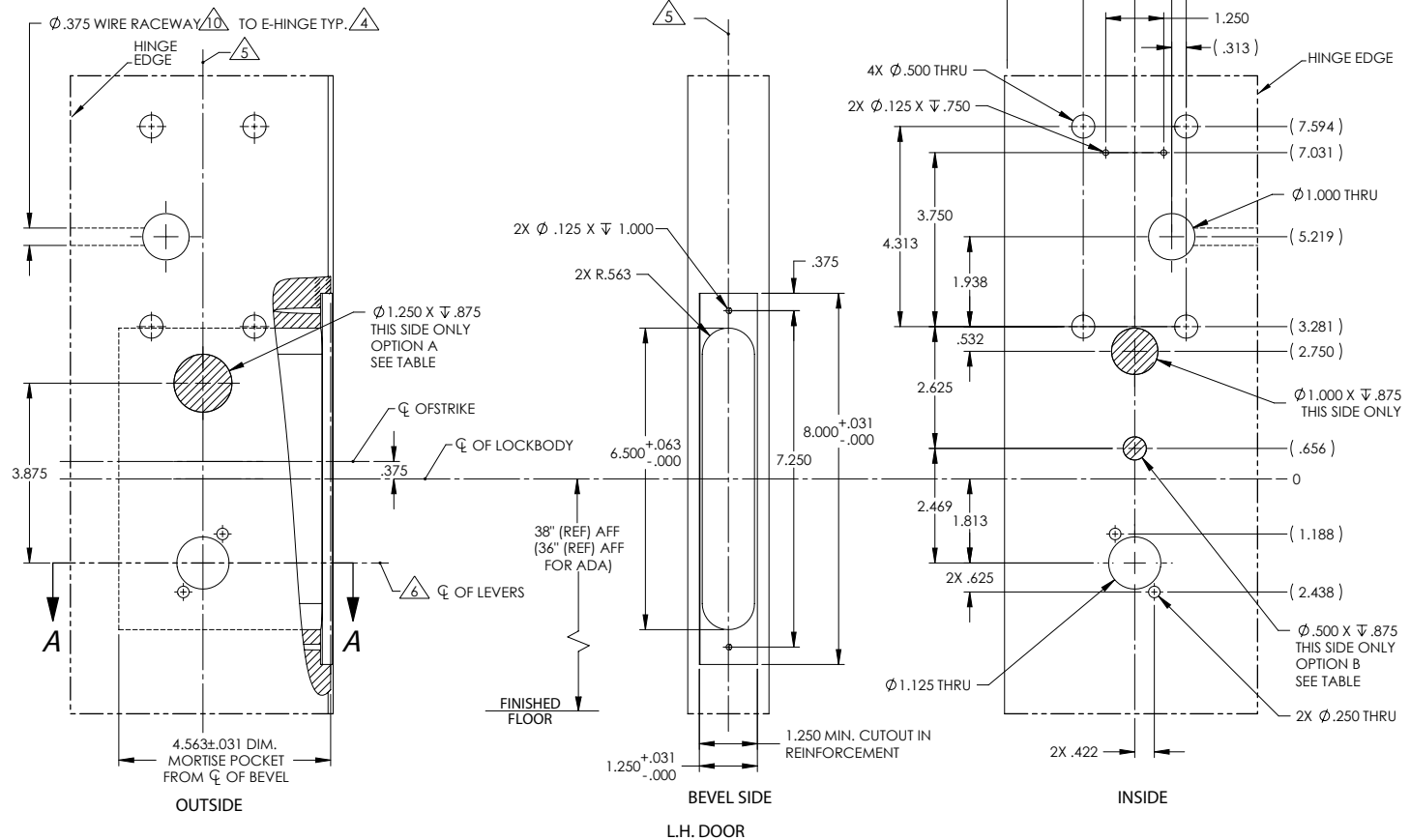
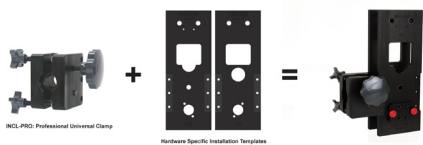

REFERENCE ONLY, NOT TO SCALE

This product is based on the depicted illustration. Pro-Lok installation tools are only "aids" for a more professional job. The actual templates received may look different in appearance because they may be designed to accommodate specific hardware features, not limited to handedness, door material, etc. Work should be done in a clean environment. Follow all recommended safety precautions outlined by the manufacturer of the tools used (not limited to: drill motor, drill bits, routers, etc) and manufacturer's hardware.

Prior to use, ALWAYS match the paper template provided by the manufacturer with your hardware to the PRO-LOK installation template. This will insure that the template is accurate and up-to-date to the hardware to be installed.

Many cutouts are oversized to accommodate the different tolerances between bit manufacturers and some cutouts are designed to be used with router collars.