

Installation Instructions:

1. Position the Latch Protector in the desired position on the door. Close the door and check that the door will close properly once the Latch Protector is installed.
2. Mark the bolt holes.
3. Drill holes for the 5/16" bolts provided and attach the Latch Protector to the door. (Depending on your application, you may need to provide other fasteners).

NOTE: If your Latch Protector hits or rubs on the frame or strike plate:

4. Sometimes a larger offset is needed between the Latch Protector and the frame. Spacers may be available from Entry Armor® Distributors and Retailers depending on the Latch Protector that you selected. The custom spacers are placed between the door and the Latch Protector and in some cases may be stacked to increase the offset or distance between the Latch Protector and the frame.

Instrucciones de Instalación:

1. Cierre la puerta y coloque el protector de pestillo en su lugar. Asegurese que la puerta cierra y abra libremente cuando instale el protector.
2. Marque los agujeros para los tornillos incluidos.
3. Taladre los agujeros de 8mm e instale el protector de pestillo a la puerta. (Dependiendo de la aplicación tal vez necesitara tornillos adicionales).

Nota: Si el protector de pestillo pega o roza el marco o la placa:

4. En algunas ocasiones una mayor distancia se necesita entre el protector de pestillo y el marco de la puerta. Los separadores hechos a la medida son colocados entre la puerta y el protector de pestillo y en algunas ocasiones pueden amontonar para incrementar la distancia entre el protector y el marco.

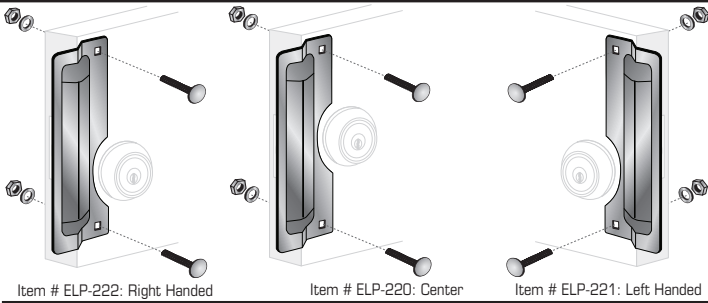

Entry Armor® Provides Products With 3 Different Levels Of Security Choices.

LEVEL 1 SECURITY

Provides Heavy-Duty Security To Deter Forced Entry And Door Jamb Separation Featuring 2 Anti-Spread Pins.

Models: ELP-240-2, ELP-250-2.

LEVEL 2 SECURITY

Provides Additional Commercial Grade Security To Deter Forced Entry And Door Jamb Separation Featuring 1 Anti-Spread Pin.

Models: ELP-240-1, ELP-250-1.

LEVEL 3 SECURITY

Provides Commercial Grade Security To Deter Forced Entry.

Models: ELP-210, ELP-220, ELP-240, ELP-250.



Need Additional Security? Look For ENTRY ARMOR® Level 1 And Level 2 Latch Protectors, Equipped With Anti-Spread Pins, To Deter Forced Entry And Door Jamb Separation.

Pro-Lok® And Entry Armor® Are Trademarks Of Weinraub Enterprises, Inc. © 2011. Made in U.S.A. www.ENTRYARMOR.com

Aluminum	=	AL
Brass	=	B
Chrome	=	C
Duronotic	=	DU
Stainless Steel	=	S

<input type="checkbox"/> ELP-220-AL UPC: 638246310463	<input type="checkbox"/> ELP-221-AL UPC: 638246311514	<input type="checkbox"/> ELP-222-AL UPC: 638246311569
<input type="checkbox"/> ELP-220-B UPC: 638246310470	<input type="checkbox"/> ELP-221-B UPC: 638246311521	<input type="checkbox"/> ELP-222-B UPC: 638246311576
<input type="checkbox"/> ELP-220-C UPC: 638246311392	<input type="checkbox"/> ELP-221-C UPC: 638246311538	<input type="checkbox"/> ELP-222-C UPC: 638246311583
<input type="checkbox"/> ELP-220-DU UPC: 638246310487	<input type="checkbox"/> ELP-221-DU UPC: 638246311545	<input type="checkbox"/> ELP-222-DU UPC: 638246311590
<input type="checkbox"/> ELP-220-S UPC: 638246310494	<input type="checkbox"/> ELP-221-S UPC: 638246311552	<input type="checkbox"/> ELP-222-S UPC: 638246311606
<input type="checkbox"/> ELP-250-AL UPC: 638246311422	<input type="checkbox"/> ELP-250-1-AL UPC: 638246310654	<input type="checkbox"/> ELP-250-2-AL UPC: 638246310708
<input type="checkbox"/> ELP-250-B UPC: 638246311439	<input type="checkbox"/> ELP-250-1-B UPC: 638246311439	<input type="checkbox"/> ELP-250-2-B UPC: 638246310715
<input type="checkbox"/> ELP-250-C UPC: 638246311446	<input type="checkbox"/> ELP-250-1-C UPC: 638246310678	<input type="checkbox"/> ELP-250-2-C UPC: 638246310722
<input type="checkbox"/> ELP-250-DU UPC: 638246311453	<input type="checkbox"/> ELP-250-1-DU UPC: 638246310685	<input type="checkbox"/> ELP-250-2-DU UPC: 638246310739
<input type="checkbox"/> ELP-250-S UPC: 638246311460	<input type="checkbox"/> ELP-250-1-S UPC: 638246310692	<input type="checkbox"/> ELP-250-2-S UPC: 638246310746